

DEEP VACUUM: ITS PRINCIPLE AND APPLICATION

Adapted from material provided by JB Industries. Reprinted with permission.

INTRODUCTION

With the *deep vacuum* method of evacuation, you are sure of your results before you leave the job. No more waiting for a callback in order to determine the results of your work. Deep vacuum is the only method you can use to tell, for sure, that a system is thoroughly dry and free of noncondensibles and leaks.

MEASURING EVACUATION: MICRONS OR INCHES?

A *micron* is a measurement of pressure starting from a perfect vacuum (no pressure) expressed in linear increments. One inch equals 25,400 microns. Be aware that when you discuss vacuum in terms of microns, you are referring to total *absolute pressure*, as opposed to gauge pressure. In addition to using a more accurate unit of measure (you can't read fractions on a Bourdon tube type gauge), you are also starting from the same measuring point (theoretical perfect vacuum).

The Bourdon tube type gauge uses atmospheric pressure as its reference point, which is constantly changing during the day. The weather forecaster always includes this reading—barometric pressure—along with the temperature. When an area on a weather map is covered by a “HIGH,” it translates into high barometric pressure, and vice versa for a “LOW.”

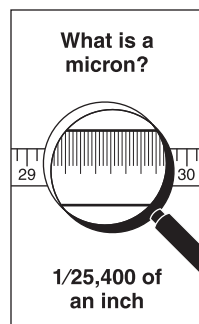

PUMPS AND HOW TO SELECT THEM

Deep vacuum pumps are probably the first item to come to mind when people think of vacuum tools

(see Figure 1). Unfortunately, the first mistake is usually made in the selection of these pumps, with reasoning that goes like this: “The larger the pump I get, the faster I can do the job.” But pump capacity has very little to do with evacuation time in refrigeration systems, as is easily seen when you examine the following facts.

The refrigeration system itself is constructed of several feet of small-diameter tubing with return bends and metering devices that offer restriction during evacuation. Compound this with the fact that service valves, when provided, have 1/4-in. male flare ports with only 3/16-in. orifices.

The only way to get more flow through a given orifice is by increasing the pressure across that orifice. But



JB INDUSTRIES, INC.

Figure 1. Typical vacuum pump

does a pump create pressure that increases the flow? No. It's easy to forget two basic principles:

- ▶ A vacuum pump creates a void toward which the system pressure flows.
- ▶ As pressure decreases in the system during evacuation, flow also decreases. Therefore, it is impossible to increase pressure or flow through a gauge port with a larger pump.

Pumps in the 1½ to 10-cfm class are adequate to handle 99% of air conditioning and refrigeration work. As a rule of thumb, the cfm rating squared equals the maximum system tonnage—i.e., a 7-cfm pump is rated for 49 tons, a 3-cfm pump is rated for 9 tons. They are all that should be purchased for service and installation. In many cases, depending on the system line sizes of large-tonnage systems, it is better to put two or more of the small, easily handled pumps at different locations. This will overcome some of the pressure drop problems and actually be faster than a single large pump.

PUMP CONSTRUCTION

Rotary-vane deep vacuum pumps are readily available and are best suited for air conditioning and refrigeration work. Piston-type pumps, because of the clearance necessary between piston and head, are incapable of producing a deep vacuum or at best are very inefficient. Many single-stage compressors, similar to hermetic compressors, will not evacuate a system into a micron range (the last inch of pressure on the compound gauge). Nor will a single-stage compressor condense any moisture vapor in the system.

Two-stage pumps (two pumps in series) have the best record in the air conditioning and refrigeration industry because they are capable of producing consistently lower pressures and are much more efficient at removing moisture vapor. The pump should be

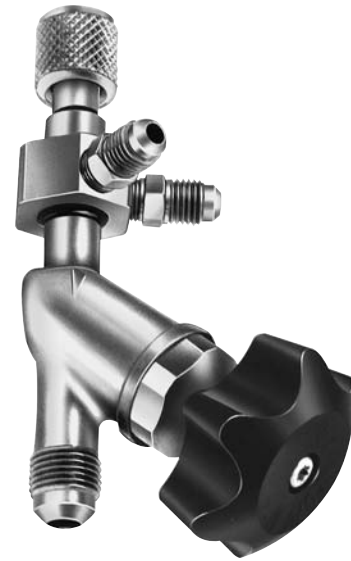
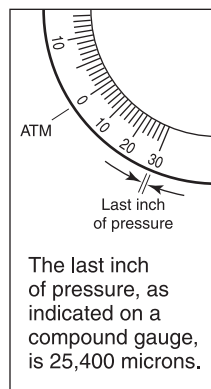

Figure 2. Blank-off valve

equipped with a blank-off valve (see Figure 2), which allows the technician to perform the isolation test (pressure rise) required in deep vacuum procedures.

The gas ballast feature should be on all pumps used for refrigeration. At the beginning of evacuation, water vapor is quickly removed. If a system is laden with moisture, it can very rapidly contaminate the oil. Through the gas ballast—a fine metering valve connected to the second stage of the pump—a small amount of relatively dry ambient air is admitted to help prevent the moisture vapor from condensing in the oil.

So far, the pump requirement has been defined as follows: You know that you will need a two-stage, rotary-vane, 1½ to 10-cfm pump with a blank-off valve and a gas ballast valve. A system is evacuated to between 300 and 400 microns, so obviously the pump should be able to produce a vacuum in the low micron range with a safety factor of at least 25 microns total absolute. Thus, the pump should be able to achieve vacuum readings of at least 25 microns total absolute. You should also look for light weight and rugged construction, because the vacuum pump will be at your side as you climb those ladders to the rooftop.

Finally, when checking out pumps, be sure to consider the issue of safety. Belt-driven units should *never* be used without belt guards—if you don't care about your own fingers, etc., give children and others exposed to machinery a chance. Hospitals and courtrooms around the world are full because of such negligence.

ELECTRONIC VACUUM GAUGES

Coupled with good procedures, which will be covered later, an electronic vacuum gauge (see Figure 3) tells you positively that you have a system free of leaks and noncondensibles. In general, these gauges are heat-sensing devices, in that the sensing element mechanically connected to the system being evacuated generates heat. The rate at which this heat is carried off changes as the surrounding gases and vapors are removed. Thus, the output of the sensing element (either thermocouple or thermistor) changes as the heat dissipation rate changes. This change in output is indicated on a meter that is calibrated in microns of mercury.

Evacuation is complete when a system holds at 500 microns. The compound gauge indicates only that a vacuum is being produced. The vacuum gauge, on the other hand, is the only tool for accurately reading that low pressure.

VACUUM GAUGE SELECTION AND ACCURACY

The electronic vacuum gauge is probably the least purchased deep vacuum tool. Yet, without one you might just as well forget about deep vacuum altogether. The most important feature in a vacuum gauge is range. If a micron gauge indicates only from 50 to 1,000 microns, you will not be able to determine whether you are pumping against a leak or against moisture. Look for an instrument that reads from 50 microns to at least 9,000 microns.

A digital display with easily read numbers gives the technician instant and continuous readout, whereas a gauge with color-coded lights displays the reading “within a range” of microns (there is a “wait” period to see whether the system is going up or down in microns).

Portable micron gauges typically operate from battery power and should have a “low battery” sensor. Some models have ac adapter capability, so you won't run out of power on the job.

Another feature to look for is a sturdy case to protect the instrument. Finally, when you buy instruments of this type, remember that you are really buying answers—and the instrument should give you these answers quickly and accurately. You get paid for adjusting refrigeration systems, not your tools.

As already noted, when you talk about micron gauges you are talking about accuracy, and gauge accuracy is affected by two factors:

- ▶ extreme temperatures (especially with exposure to the summer sun on a hot rooftop or pavement)
- ▶ sensor contamination.

The vacuum sensor is factory-calibrated on air. If refrigerant gas or oil is drawn into the vacuum sensor of a remote reading unit or a unit connected to the pump during the system evacuation, the gas



JB INDUSTRIES, INC.

Figure 3. Digital vacuum gauge

will cause an erroneous reading. Any oil entering into the vacuum sensor via the hose will also affect gauge accuracy. Improper shutdown of a pump after evacuation and loss of power will suck back oil and contaminate the hose and micron gauge.

A hose used for charging or testing will contain droplets of system oil spurted into the hose when the Schrader valve is opened. If this same hose is used on the hookup to the gauge, oil will collect in the gauge sensor. This can be prevented by using a dedicated hose (preferably an O-ring type) for evacuation.

EVACUATING THROUGH A GAUGE MANIFOLD

You may evacuate through a gauge manifold if—and only if—it is O-ring sealed, piston construction. Other types leak under vacuum. Next look at the design of the center port. In order to handle the full capacity of both the high and low sides, the center intake should have a double-size flow path throughout its length.

Deep vacuum has its own unique properties that require a leak-proof design not only in the manifold, but in all components. The only connecting lines that are absolutely vacuum-tight are soft copper tubing or flexible metal hose. Charging and testing hoses are designed for pressure. Even with the advanced technology of today's hoses, permeation through the hose compound still exists. When you check pressure rise, the atmosphere will permeate to the lower pressure in the hoses and the micron reading will slowly rise.

Another source of leakage is the gasket seal in valve and hose couplers. This seal is designed for charging and will not give the perfect seal required in deep vacuum service. An O-ring seal coupler, as shown in Figure 4, forms around irregularities in the flare fitting. When the coupler is screwed down, you get a metal-to-metal seat and the O-ring lays around the lip of the flare to give a positive seal.

CONNECTING LINES

The simplest hookup is a gauge manifold with two 1/4-in. ID connecting lines to the system and a 3/8-in.

connection to the pump via line or fittings. Much has been said and written regarding line size, which might lead you to believe that the bigger line you connect, the faster job you'll do. This would be true except for the fact that the compressor's service valves have 3/16-in. orifices. Therefore, you need only keep the ID of the connecting lines larger than 3/16 in. This is one of the limiting time factors in evacuation.

Evacuation should always be done from both the low side and the high side of the system. This can save as much as 75% of the time required for evacuating from only one side. Short connecting lines also will save some time—but not nearly as much as some people claim. In relation to the lengths of tubing in the system, you add very little restriction via connecting lines.

BEFORE YOU START

It is a good idea to attach the micron gauge to the vacuum pump to make sure that the pump pulls down to at least 50 microns. If it doesn't, your pump is contaminated and the oil should be changed. Do not shut off the blank-off valve on the pump and expect the gauge to hold a vacuum, because the gauge will fall back to atmosphere. The reason for this is that the sensor is too close to the pump and the sensor of the micron gauge doesn't have time to equalize.

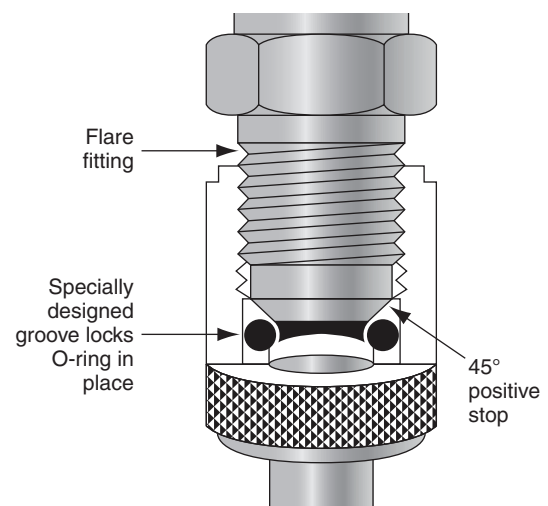

Figure 4. Deep vacuum O-ring coupler cutaway

GENERAL MICRON GAUGE HOOK-UP

When designing your hook-up system, choose from the following hoses, valves, and couplers designed for leak-proof service in a deep vacuum environment:

- ▶ Use a ¼-in. metal hose and a ⅜-in. metal hose with O-ring couplers, hooked up through the manifold, pump, and (if desired) to the micron gauge.
- ▶ Use a quick coupler tee with an O-ring seal. Since the most accurate readings are obtained at the compressor's high or low sides, use this arrangement to tee off the gauge.
- ▶ Use a ball valve with an O-ring quick coupler to valve off the gauge before charging. Remember that, depending on the instrument, the sensors of the electronic gauge will not take pressure beyond 1 to 100 lb. Depending on the hook-up, use this arrangement with a metal hose or coupler.

DISPELLING THE ARGUMENT OF "NO DEEP VAC ON HEAT PUMPS"

The word "sublimation"—the ability of moisture to change directly from solid ice to vapor without passing through a liquid state—is commonly used in discussions of vacuum. This phenomenon is observed when, for example, laundry is hung out in the winter and freezes solid. Still, in time it does dry (due to sublimation). If refrigeration system lines are in a cold ambient, it is possible to have ice in the system. It will be removed during evacuation. Of course, the addition of heat (heat gun only) at these cold spots speeds up the job.

PRESSURE RISE TEST

It was mentioned previously that the only difference between deep vacuum and the methods of the past is that now you can measure what you have done.

This is called the "pressure rise test." It is performed when the sensor reads between 300 and 400 microns, and is done using copper tubing or metal hose to the high and low sides.

Close the blank-off valve on the pump. This will isolate the gauge from the pump. Wait for a minimum of 5 minutes to a maximum of 20 minutes to allow system pressure to equalize. The reading you see at the end of this test will be very close to what you actually have in the system. As shown below, a rapid rise to atmospheric pressure indicates a leak, while a slower rise to around 1,500 microns indicates that moisture is present.

READINGS AFTER 5–20 MINUTES	
Under 500 microns	Evacuation complete
Slow rise to 1,500 microns	Moisture
Rapid rise to ATM	Leak

There are many recommendations regarding evacuation levels, some of which state: "Evacuate the system to below 200 microns." This should *not* be considered. Note that the word "system" is used here, because it is possible to evacuate piping or some component other than the compressor to below this level. Refrigeration oil has a vapor pressure and, by going below 200 microns, you will degas particles of the refrigeration oil. Be aware that if you change the makeup of the oil, it will no longer be a true lubricating oil.

EVACUATION BRINGS OUT THE WORST IN A SYSTEM

Remember that hydrofluoric and hydrochloric acids (and their companion, moisture) can and do collect in oil. They effectively destroy pull-down and act as an abrasive—if left sitting in an idle pump, they will rust and corrode internal surfaces. Deep vacuum pumps need a fill or two for every job.

In order for your pump to pull a near perfect vacuum, oil must be clean and moisture-free throughout evacuation. Take a few minutes during and after each job to drain, flush, and refill. Doing so will keep your pump running at peak performance and maintenance-free for years to come.

Always store your vacuum equipment plugged or capped to prevent contamination due to condensation and dirt. Because a slight cut or dirt on the O-ring seals can cause leaks, the mating flare fitting faces should be wiped and checked for damage before hook-up. Vacuum pump oil makes a fine lubricant at these connections.



1666 Rand Road Des Plaines, IL 60016 800-297-5660 www.rses.org