

T30600

RATCHETING FLARE TOOL

OPERATING INSTRUCTIONS

1. Cut and ream tubing.
2. Back off feed screw handle and clamp screw to permit flaring bars to slide freely through yoke. Slide yoke to hinged end of flaring bars.
3. Insert tube into proper size opening and close flaring bars. Push tube up from bottom of tool until it is even with top of flaring bars.

Note: Oversize or undersize flares can be made by adjusting tube position slightly above or below the top of flaring bars.

4. Slide yoke forward over tube until arrow on yoke meets line on flaring bars. Tighten clamp screw firmly.
5. Ratchet the feed screw handle clockwise until pressure kick-out releases. A few additional turns before backing off with burnish flare.
6. Back off feed screw handle as far as it will go. Release clamp screw and slide yoke back. Remove tube. If tube tends to stick, tighten clamp screw against tapered end of bars. This action will force bars open.

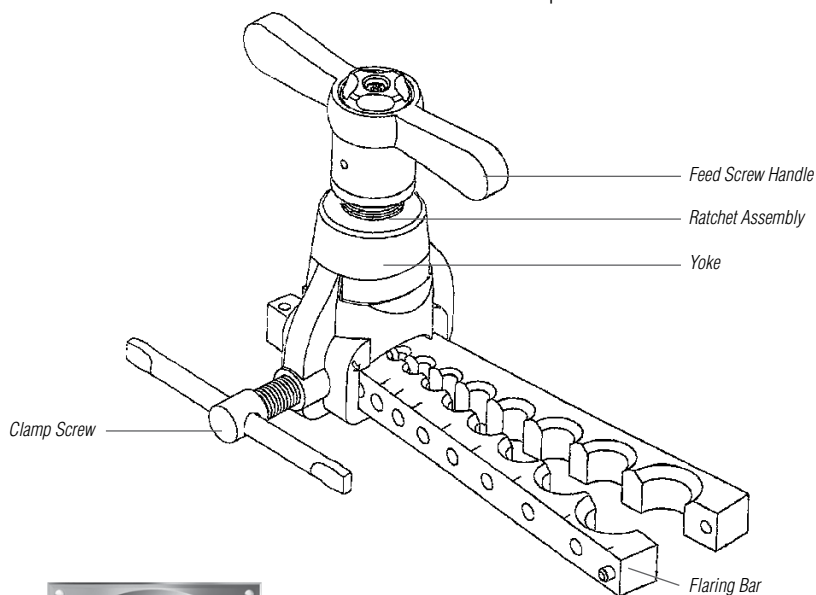

JB INDUSTRIES