



PLATINUM FORCE

7.2 CFM

ADVANCED GRADE VACUUM PUMP

CONTENTS

Introduction	2	Repair Parts	3
Motor Specifications	2	Troubleshooting	4
Operation	2	Return for Repair	4
Pump Maintenance	2	Warranty	4
Features	3		



AMERICAN-MADE TO TACKLE ANY JOB.



DC
MOTOR

PLATINUM® FORCE DC-6EDC VACUUM PUMP	
CFM	7.2 CFM
MOTOR	1/2 HP DC Motor
VOLTAGE	115v/230v
INTAKE PORT	1/2" x 1/4" x 3/8"
OIL CAPACITY	25 oz (739 cc)
WEIGHT	24 lbs (10.9kg)



WARNING: UNIT DRAINED OF OIL FOR SHIPMENT. DO NOT OPERATE WITHOUT ADDING OIL.



OPERATING MANUAL

IMPORTANT



WARNING: UNIT DRAINED OF OIL FOR SHIPMENT. DO NOT OPERATE WITHOUT ADDING OIL.

INTRODUCTION

Each PLATINUM® vacuum pump has been factory tested to guarantee 15 microns (25,400 Microns = 1 Inch of Hg) or better, and listed CFM performance. The serial number has been recorded. Complete and mail the enclosed Warranty Registration Card or register online at www.jbind.com within 10 days of purchase to validate your warranty.

NOTE: PLATINUM® pumps are not to be used on Ammonia or Lithium Bromide (salt water) systems. Pump maintenance is the responsibility of the owner.

MOTOR SPECIFICATIONS

Pump and oil must be above 30°F. Line voltage must be equal to motor nameplate $\pm 10\%$. Normal operating temperature is approximately 160°F, which is hot to the touch. Line voltage and ambient conditions can slightly affect this. Motor has automatic resetting thermal overload protection.

The PLATINUM® is designed for continuous duty and will run for extended periods without overheating.

OPERATION

The following procedures will prevent oil from being drawn into the pump cartridge and creating hard start-up.

Start-up: Close both sides of manifold and make connection to vacuum pump or auxiliary blank-off equipment. Open one intake port and isolation valve, close gas ballast valve and start pump. Make vacuum connections (**Figure 1**).

Crack gas ballast valve for the first part of the evacuation procedure. After pump quiets down from initial volume of air, close valve and continue evacuating. Failure to close valve will result in poor pump performance.

Shutdown: Close isolation valve and open gas ballast valve all the way. Continue running pump for 2-3 seconds. With gas ballast valve still opened, stop pump and then close valve. Remove hose connections and cap intakes (**Figure 1**).

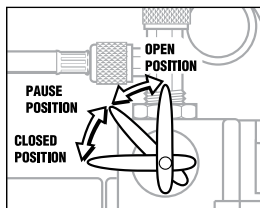

Isolation (Blank-Off) valve: Quarter-turn on/off. No additional valve needed to isolate system.

When checking pressure rise, slowly turn handle counter-clockwise. Pause at 45°. Valve is completely closed at 90°.

Figure 1

PUMP MAINTENANCE

In order to make the best use of your investment, familiarize yourself with the features and operating instructions before starting pump. With routine care and following proper maintenance guidelines, your PLATINUM® will give you years of reliable service. PLATINUM® pumps are designed for deep vacuum work in air conditioning and refrigeration systems.

Adding Oil

Step 1: Remove cap (DV-240DC) or filter (DV-285DC) from pump. One-shot, full quart oil fill brings oil to top of the oil level line. (Figure 2)

Step 2: Replace filter.

If oil level is too low, you will hear air out of the exhaust. If oil level is too high, excess oil will be blown out of the exhaust.

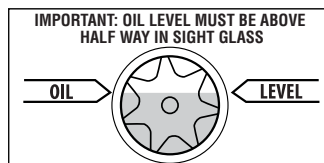

Figure 2

IMPORTANT: Use oil specifically refined for deep vacuum pumps. Using oil not refined for deep vacuum pumps and/or operating with contaminated oil will void warranty.

Pump oil should be changed after each use. If system is heavily contaminated, oil may have to be changed several times during evacuation. After initial fill up, it is best to check oil level with pump running.

After evacuation, oil contains rust forming water and corrosive acids. Drain immediately while pump is warm.

Changing Oil

To reach deep vacuum, PLATINUM® pumps need clean, moisture-free oil throughout evacuation. Care should be taken to avoid contact on skin and clothing when changing oil. Used oil should be disposed of in the DV-T1 TANK Oil Caddy after every evacuation while the pump is warm and the oil is thin.

Step 1: Place the TANK on a level surface. Unscrew black plug in drain base to open.

Step 2: Place vacuum pump in the cradle and drain pump.

Step 3: When pump has finished draining, replace black plug. The TANK can hold up to five oil changes.

Step 4: Close oil drain valve on pump. Remove oil fill plug and fill to top of oil level line with BLACK GOLD Pump Oil (**Figure 2**). Replace oil fill plug.

Flushing Oil

Step 1: Always drain pump before flushing. If the oil is badly contaminated, flushing may be necessary.

Step 2: While oil drain is open slowly pour 1/3 to 1/2 cup of BLACK GOLD Pump Oil into the intake connection while pump is running.

Step 3: Repeat as required until contamination is removed from oil reservoir, pump rotors, vanes and housing.

Step 4: Dispose of all oil used in flushing of pump.

WARNING: DO NOT START PUMP BEFORE ADDING OIL

Black Gold Pump Oil

Acts as a coolant, lubricant and sealant—simultaneously.



DV-T1 Tank Pump Oil Caddy

- Change oil between jobs
- No more mess and spills
- Easy, convenient, and portable
- Capacity for five oil changes



FEATURES



PLATINUM FORCE REPAIR PARTS DV-6EDC

Repair parts can be ordered from your local JB wholesaler. When ordering please provide the following information:

- Model number
- Serial number
- Part number and description

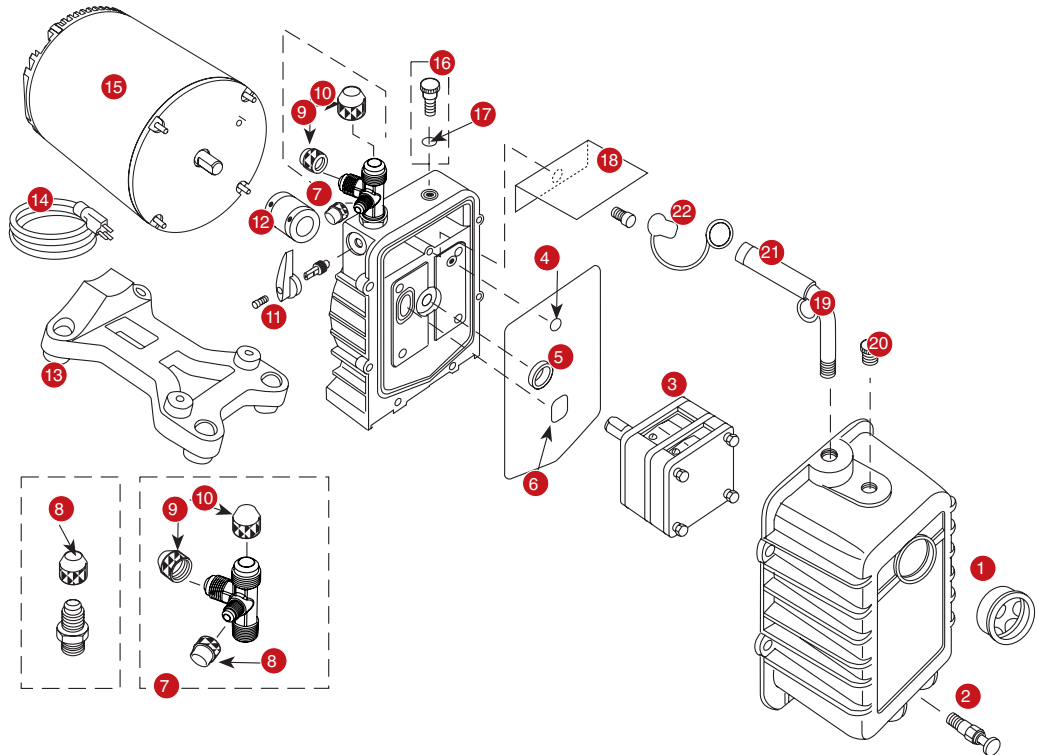

REF.NO.	PART NO.	DESCRIPTION
1	PR-1	Sight glass
2	PR-2	Drain valve
3	PR-304	Cartridge
4	PR-211	Trap o-ring, gas ballast
5	PR-3	Shaft seal
6	PR-315	Trap o-ring, intake
7	PR-78	Angled intake tee with caps
8	NFT5-4	1/4" O-ring, cap
9	NFT5-6	3/8" O-ring, cap
10	NFT5-8	1/2" O-ring, cap
11	PR-209	Plastic isolation valve handle and screw w/stem, O-rings and retainer (not interchangeable w/PR-210)

REF.NO.	PART NO.	DESCRIPTION
12	PR-208	Flexible coupler
13	PR-59	Base foot
14	PR-49	IEC 10 ft. locking cord
15	PR-607	DC Motor
16	PR-7	Gas ballast valve w/o-ring
17	P90009	O-ring, gas ballast valve
18	PR-40	Splash guard and screw
19	PR-75	Cushioned handle w/lift ring 1/2" NPT and DV-EP-8
20	PR-22	Oil fill plug w/o-ring
21	PR-501	Cushion and cap 1/2" NPT
22	DV-EP8	Tethered safety cap 1/2" NPT

TROUBLESHOOTING

SYMPTOM	POSSIBLE CAUSE(S)	CORRECTIVE ACTION
Pump hard to start	A. Power cord not plugged in securely B. Motor switch not on C. Pump temperature below 30°F D. Pump has not been shut down properly	A. Plug power cord in securely B. Turn motor switch to ON position C. Warm up pump to 30°F and turn motor switch on D. Follow proper start up and shut down procedures Step 1: Remove 1/4" cap Step 2: Move blank-off valve to OPEN position Step 3: Turn pump on Step 4: Run 2 to 3 seconds and close blank-off valve PROPER START UP AND SHUT DOWN PROCEDURES: Step 1: Close blank-off valve Step 2: Open gas ballast valve Step 3: Run 2 to 3 seconds Step 4: Shut pump off Step 5: Close gas ballast valve
Pump won't pull deep vacuum In order for your pump to pull to a near perfect vacuum, oil must be clean and moisture-free throughout evacuation.	A. Contaminated oil B. Oil level too low C. Air leak in system being evacuated D. Pump inlet fittings missing or not tightened E. Coupler slipping F. Missing or damaged seals or o-rings	A. Change oil B. Add oil C. Locate and repair leak(s) D. Clean or replace o-ring E. Tighten coupler set screws to flats of cartridge and motor F. Replace damaged seals or o-rings Step 1: With isolation valve closed, start pump. Oil level should be to the top of the oil level line embossed on the front of the pump's cover. Just a teaspoon low can affect the ultimate vacuum. Step 2: Flush pump and refill with fresh oil. Step 3: Check all connections to pump and system for damaged or missing o-rings. If brass adapters are being used, make sure copper gaskets are in place.
Oil drips from point where shaft enters the pump housing	Damaged shaft seal	Replace shaft seal
Pump shuts down and will not start	A. Thermal overload may be open B. Low Battery (DV-142-FLEX or DV-85-FLEX)	A. Step 1: Disconnect pump from system Step 2: Wait approximately 15 minutes for motor to cool Step 3: Turn pump on Step 4: If it cycles off again, return for repair B. Check battery charge; re-charge if necessary
Pump cycles on and off from a completely cold start and then runs smoothly	A. Oil backed up into cartridge and was being cleared out B. Pump has not been shutdown properly	Step 1: Remove 1/4" cap Step 2: Turn pump on
Motor just hums	If pump has been dropped, the armature in motor may be out of alignment with the motor's bell housing	Step 1: Set pump on bench with motor standing up Step 2: Loosen the four motor bolts Step 3: Shake motor and re-tighten motor bolts Step 4: Start pump If this doesn't work, the pump most likely will need to be sent in for repair.
Motor runs, but no suction	A. Flexible coupler is either broken or loose	Step 1: Set pump on bench with motor standing up Step 2: Look between motor and pump housing from the bottom to see if the flexible part of the coupler is split or broken. If the coupler is not broken, the coupler may be spinning on either the shaft to motor or cartridge. Step 3: Replace cartridge. Instructions at www.jbind.com - Support - User Manuals.

WARRANTY

PLATINUM® PRO pumps are warranted against defects in materials and workmanship for two years OTC—not changing oil will void warranty.

JB products are guaranteed when used in accordance with our guidelines and recommendations. Warranty is limited to the repair, replacement, or credit at invoice price, (our option) of products which in our opinion are defective due to workmanship and/or materials. In no case will we allow charges for labor, expense or consequential damage. Repairs performed on items out of warranty will be invoiced on a nominal basis; contact wholesaler for details. Product Warranty Registration, Limited Warranty and OTC Warranty are available online at www.jbind.com.

RETURN FOR REPAIR

In the event your pump requires repair, please contact the JB Wholesaler the pump was purchased from. JB Wholesalers contact JB Customer Service Department to obtain a Return Goods Authorization (RGA) number. Ensure that all returned products are packed to avoid any

damage in shipment. Paperwork should be placed in a separate plastic bag and should include JB's assigned RGA number, a description of the problem and any customer assigned repair or purchase order number, if applicable.

Contact Customer Service for RGA number:

800.323.0811 Toll-free phone, 800.552.5593 Toll-free fax

Customers in Alaska, Arizona, California, Idaho, Montana, Nevada, Oregon, Utah, and Washington have the option of sending vacuum pump repairs to JB or Merced.

JB Industries

RGA# _____

601 N. Farnsworth Ave.

Aurora, IL 60505

Merced AC Equipment Service

RGA# _____

805 S. Fremont

Alhambra, CA 91803



SCAN TO FOLLOW US!



JB INDUSTRIES